



CATÁLOGO DE REPUESTOS

WWW.MIXERLONDON.CL

CATEGORÍAS

- BOMBA HIDRÁULICA
- CANOAS Y BUZONES
- CARDÁN
- CIRCUITO DE ACEITE
- REDUCTOR Y MOTOR
- RODILLOS
- SISTEMA DE AGUA
- SISTEMA ELÉCTRICO
- SISTEMA NEUMÁTICO

BOMBA HIDRÁULICA

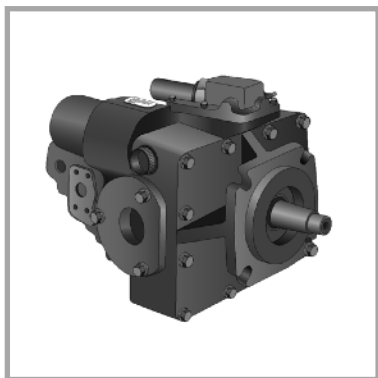

Código: M-SH-B 01
Bomba Eaton Serie 54
REPTO CW



Código: M-SH-B 02
RodilloControl RE



Código: M-SH-B 03
Kit Control RE con
válvula



Código: M-SH-B 04
Válvula control RE

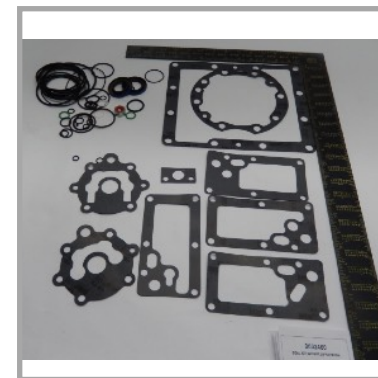

Código: M-SH-B 05
Kit de sellos bomba
Eaton Serie 54

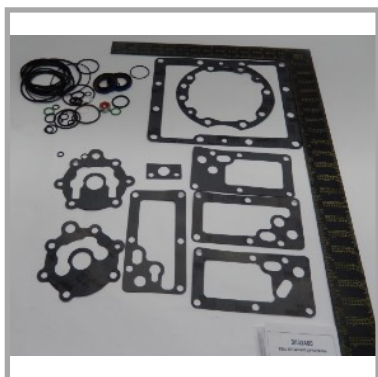

Código: M-SH-B 06
Kit de sellos bomba
Eaton Serie 46



Código: M-SH-B 07
Empaquetadura válvula
control RE



Código: M-SH-B 08
Kit de sellos eje de la
bomba



Código: M-SH-B 09
Empaquetadura control
RE



Código: M-SH-B10
Válvula bypass control
RE

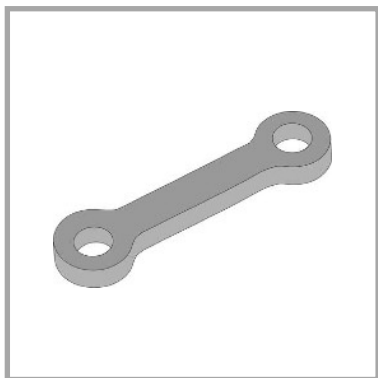

Código: M-SH-B 11
Eslabon de unión



Código: M-SH-B 12
Bomba de carga



Código: M-SH-B 13
Spool control RE, giro



Código: M-SH-B 14
Bobina control de giro



Código: M-SH-B 15
Bobina pausa/stop



Código: M-SH-B 16
Spool control RE, Dia.
1/2", pausa/stop



Código: M-SH-B 17
Spool control RE, Dia.
5/8", pausa/stop



Código: M-SH-B 18
Spool block alza canoa



Código: M-SH-B 19
Bobina alza canoa



Código: M-SH-B 20
Block alza canoa



Código: M-SH-B 21
Bobina control EP



Código: M-SH-B 22
Spool, CEC



Código: M-SH-B 23
Spool, CEC



Código: M-SH-B 24
Spool control EP



Código: M-SH-B 25
Bobina 28W, 12V con diodo



Código: M-SH-B 26
Bomba alza canoa



Código: M-SH-B 27
Kit valvula alza canoa



Código: M-SH-B 28
Bobina de válvula alza canoa

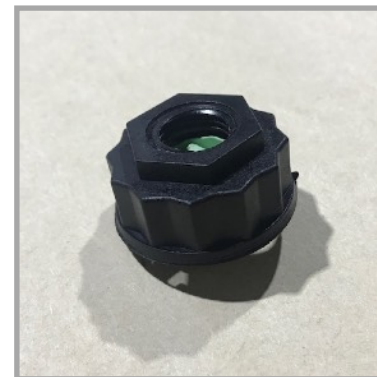

Código: M-SH-B 29
Tuerca válvula bobina alza canoa



Código: M-SH-B30
Cilindro alza canoa principal doble acción



Código: M-SH-B 31
Cilindro alza canoa
principal simple acción



Código: M-SH-B 32
Manifolld plegador
hidraulico canoa



Código: M-SH-B 33
Cilindro plegador
hidraulico

CANOAS Y BUZONES



Código: M-CB 01
Canoa principal



Código: M-CB 02
Canoa principal
extendida



Código: M-CB 03
Canoa plegable



Código: M-CB 04
Canoa auxiliar acero



Código: M-CB 05
Canoa auxiliar aluminio



Código: M-CB 06
Buzón de carga

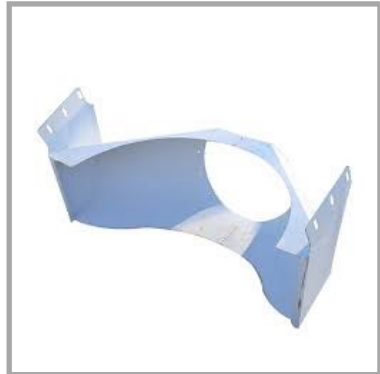

Código: M-CB 07
Buzón de descarga



Código: M-CB 08
Goma buzón de
descarga



Código: M-CB 09
Soportes canoa auxiliar



Código: M-CB 10
Manilla fijación canoa
auxiliar



Código: M-CB 11
Correa fijación canoa
auxiliar



Código: M-CB 12
Seguro canoa principal

CARDÁN



Código: M-SH-C 01
Cárdán bomba
hidráulica



Código: M-SH-C 02
Cruceta cardán corto



Código: M-SH-C 03
Flange cardán - PTO



Código: M-SH-C 04
Machón bomba
hidráulica



Código: M-SH-C 05
Kit fijación cardán

CIRCUITO DE ACEITE



Código: M-SH 01
Visor nivel de aceite



Código: M-SH 02
Radiador sistema hidráulico (completo)



Código: M-SH 03
Soporte filtro de aceite



Código: M-SH 04
Filtro de aceite



Código: M-SH 05
Vacuómetro



Código: M-SH 06
Estanque de aceite



Código: M-SH 07
Estanque de aceite plástico



Código: M-SH 08
Filtro estanque de aceite



Código: M-SH 09
Respirador estanque de aceite

REDUCTOR Y MOTOR



Código: M-RM 01
Reductor ZF, Modelo
P-7300



Código: M-RM 02
Rodamiento del
reductor



Código: M-RM 03
Retén del reductor



Código: M-RM 04
Visor nivel de aceite
reductor ZF



Código: M-RM 05
Motor Eaton serie 54



Código: M-RM 06
Motor Eaton serie 46

RODILLOS



Código: M-RD 01
Rodillo completo

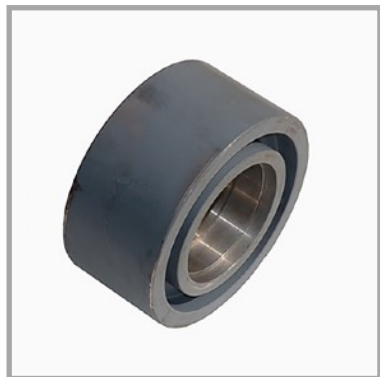

Código: M-RD 02
Rodillo



Código: M-RD 03
Eje del rodillo



Código: M-RD 04
Sello del rodillo



Código: M-RD 05
Sello rodamiento



Código: M-RD 06
Sello paño



Código: M-RD 07
Espaciador



Código: M-RD 08
Soporte rodillo

SISTEMA DE AGUA



Código: M-SA 01
Estanque de agua 65 Gal



Código: M-SA 02
Estanque de agua 90 Gal



Código: M-SA 03
Estanque de agua 125 Gal



Código: M-SA 04
Tubo de nivel estanque de agua



Código: M-SA 05
Válvula de drenaje



Código: M-SA 06
Bola de nivel



Código: M-SA 07
Regulador de presión



Código: M-SA 08
Manómetro 100 PSI

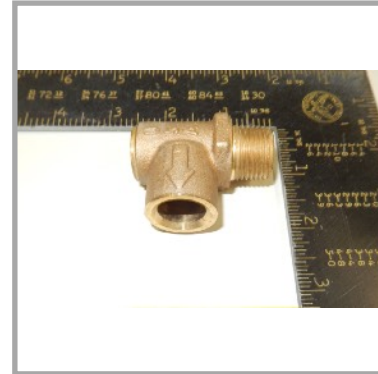

Código: M-SA 09
Válvula de alivio estanque de agua



Código: M-SA 10
Kit tapa de estanque de agua



Código: M-SA 11
Sello tapa estanque de agua



Código: M-SA 12
Empaquetadura estanque de agua



Código: M-SA 13
Tapa estanque de agua



Código: M-SA 14
Resorte tapa estanque de agua



Código: M-SA 15
Válvula limitadora de presión



Código: M-SA 16
Válvula control estanque de agua



Código: M-SA 17
Tee



Código: M-SA 18
Boquilla manguera de lavado

SISTEMA ELÉCTRICO



Código: M-SE 01
Ventilador del radiador,
con motor



Código: M-SE 02
Arnés eléctrico del
radiador

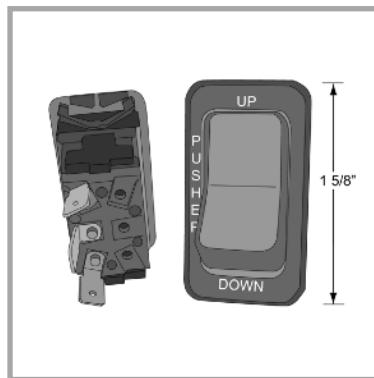

Código: M-SE 03
Switch rocker eje
alzable

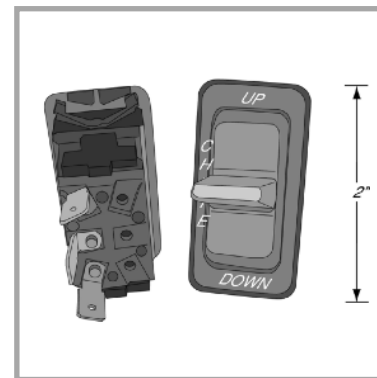

Código: M-SE 04
Switch rocker canoa
Up/Down

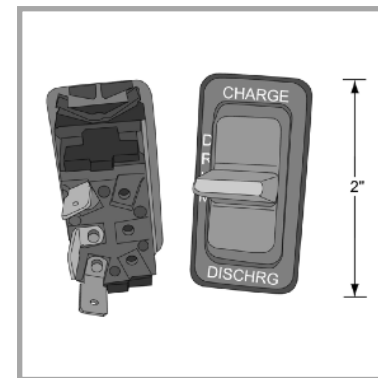

Código: M-SE 05
Switch giro Betonera
Charge/Discharge



Código: M-SE 06
Switch rocker On/Off

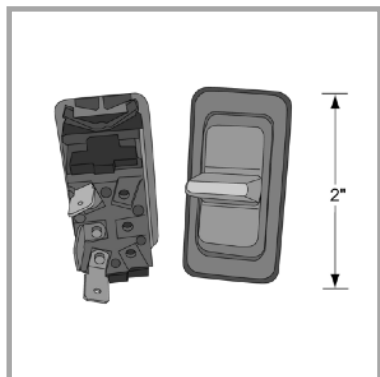

Código: M-SE 07
Switch doble porfiado
con paleta



Código: M-SE 08
Switch palanca On/Off



Código: M-SE 09
Switch palanca On/Off/
On, mantenido



Código: M-SE 10
Switch palanca On/Off/
On, porfiado



Código: M-SE 11
Switch rocker, Charge/
Discharge, momentaneo



Código: M-SE 12
Boton descarga



Código: M-SE 13
Switch rocker Start/Stop



Código: M-SE 14
Protector de goma para
switch



Código: M-SE 15
Control remoto

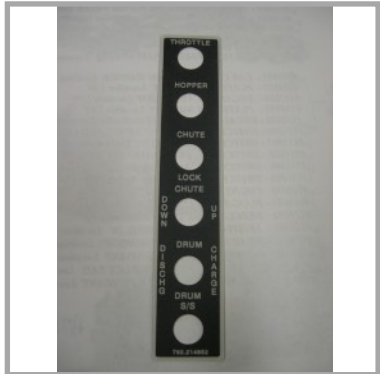

Código: M-SE 16
Placa control remoto

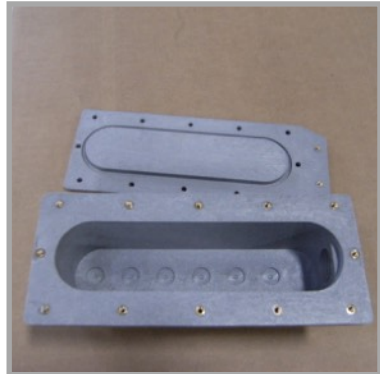

Código: M-SE 17
Carcasa control remoto



Código: M-SE 18
Tornillos carcasa control
remoto



Código: M-SE 19
Conector control remoto
con flexible

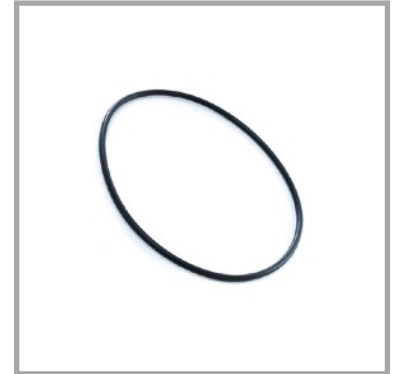

Código: M-SE 20
O´Ring control remoto



Código: M-SE 21
Soporte control remoto



Código: M-SE 22
Sensor temperatura
aceite



Código: M-SE 23
Termostato radiador
140°



Código: M-SE 24
Termostato radiador
180°



Código: M-SE 25
Sensor presión, doble
polo



Código: M-SE 26
Control maestro

SISTEMA NEUMÁTICO



Código: M-SN 01
Válvula de bloqueo
canao



Código: M-SN 02
Válvula elevación buzón
de carga



Código: M-SN 03
Válvula eje alzable



Código: M-SN 04
Regulador de aire,
manifold



Código: M-SN 05
Manómetro presión de
aire



Código: M-SN 06
Manifold, eje, buzón,
canao

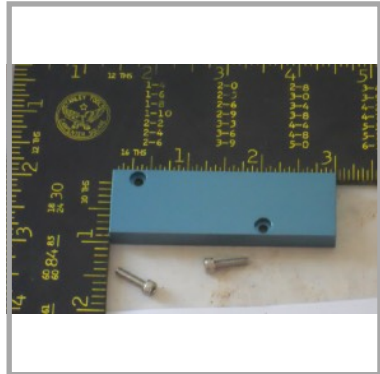

Código: M-SN 07
Tapa puerto válvula



Código: M-SN 08
Filtro coalescing



Código: M-SN 09
Kit drenaje



CONTACTO

+56 22 836 4400 / info@mixerlondon.cl / Gran Av. José Miguel Carrera 13876 - San Bernardo